

1-Line, Uni-directional, Transient Voltage Suppressors

Descriptions

The ESD4V5H401TR is a uni-directional TVS (Transient Voltage Suppressor). It is specifically designed to protect sensitive electronic components that may be subjected to ESD (Electrostatic Discharge), EFT (Electrical Fast Transients) and Lightning. It is particularly well-suited for cellular phones, portable device, digital cameras, power supplies and many other portable applications because of its small package

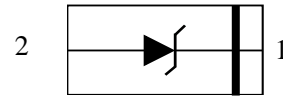

The ESD4V5H401TR may be used to provide ESD protection up to $\pm 30\text{KV}$ Air, $\pm 30\text{KV}$ contact compliance to IEC61000-4-2, and withstand peak pulse current up to 150A ($8/20\mu\text{s}$) according to IEC61000-4-5.



DFN1610-2L

The ESD4V5H401TR is available in DFN1610-2L package. Standard products are Pb-free and Halogen-free.

Features

- Stand-off voltage: $\pm 4.5\text{V}$ Max
- Transient protection for each line according to IEC61000-4-2 (ESD): $\pm 30\text{KV}$ Air, $\pm 30\text{KV}$ contact IEC61000-4-5 (Surge): 150A ($8/20\mu\text{s}$)
- Solid-state silicon technology
- Low leakage current

Applications

- Cell phone handsets and accessories
- Personal Digital Assistants (PDAs)
- Notebooks, Desktops, and Servers
- Portable Instrumentation
- Digital Cameras
- CAR/MID DVD/MP3/MP4/PMP Players

Order information

Device	Marking	Shipping
ESD4V5H401TR	H4T	3000/Tape&Reel

Absolute maximum ratings

Parameter	Symbol	Rating	Unit
Peak pulse current ($t_p = 8/20\mu s$)	I_{PP}	150	A
ESD according to IEC61000-4-2 air discharge	V_{ESD}	± 30	kV
ESD according to IEC61000-4-2 contact discharge		± 30	
Operating temperature	T_{OP}	-40~85	$^{\circ}C$
Operation junction temperature	T_J	125	$^{\circ}C$
Lead temperature	T_L	260	$^{\circ}C$
Storage temperature	T_{STG}	-55~150	$^{\circ}C$

Electrical characteristics (TA=25 $^{\circ}C$, unless otherwise noted)

Parameter	Symbol	Min	Typ	Max	Unit	Test Condition
Reverse Working Voltage	V_{RWM}			± 4.5	V	$I_R = 0.2\mu A$
Breakdown Voltage	V_{BR} (PIN 1 TO PIN 2)	5.2			V	$I_T = 1mA$
Reverse Leakage Current	I_R			0.2	μA	$V_R = 4.5V$
Forward Voltage	V_F (PIN 2 TO PIN 1)		0.7		V	$I_F = 10mA$
Clamping Voltage	V_C (PIN 1 TO PIN 2)			7.5	V	$I_{PP} = 1A(8/20\mu s \text{ pulse})$
				18.0	V	$I_{PP} = 150A(8/20\mu s \text{ pulse})$

Electrical performance curve

Symbol	Parameter
V_{RWM}	Peak Reverse Working Voltage
I_R	Reverse Leakage Current @ V_{RWM}
V_{BR}	Breakdown Voltage @ I_T
I_T	Test Current
I_{PP}	Maximum Reverse Peak Pulse Current
V_C	Clamping Voltage @ I_{PP}
P_{PP}	Peak Pulse Power
C_J	Junction Capacitance
I_F	Forward Current
V_F	Forward Voltage @ I_F

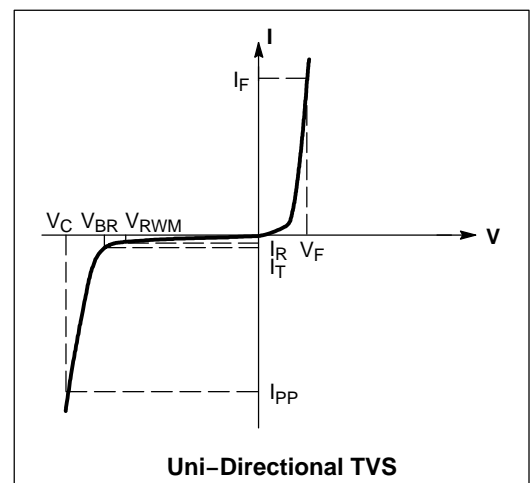

Typical characteristics ($T_A=25^\circ\text{C}$, unless otherwise noted)

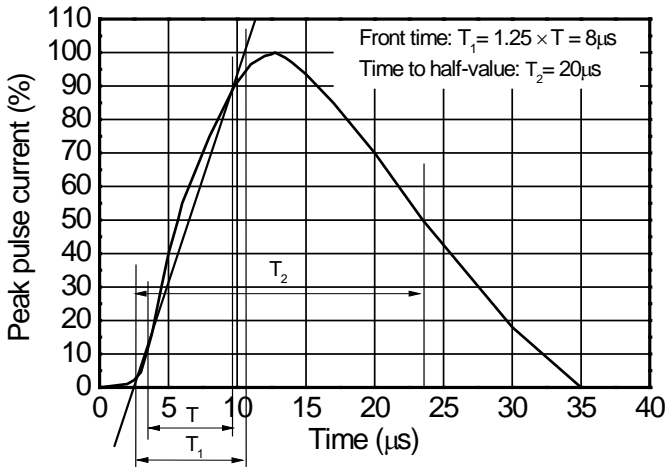

8/20 μs waveform per IEC61000-4-5

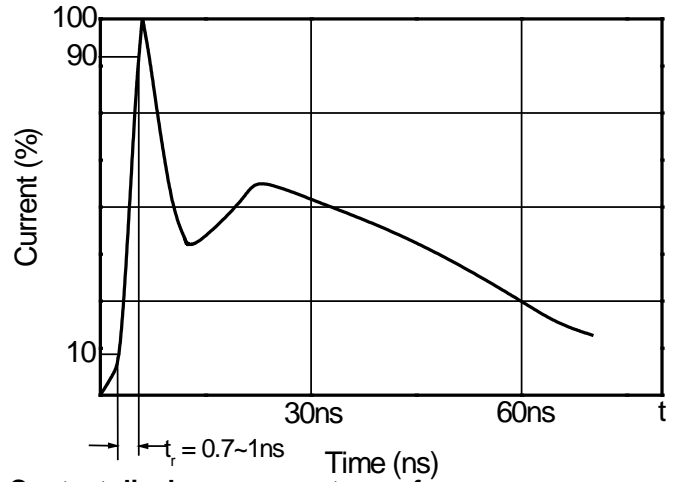

Contact discharge current waveform per IEC61000-4-2

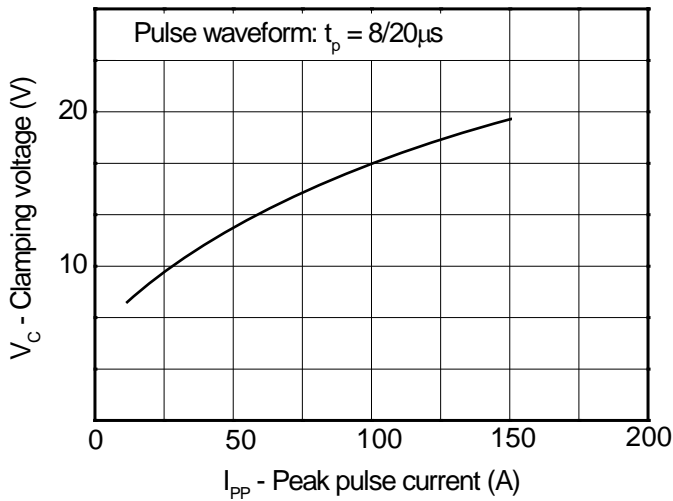

Clamping voltage vs. Peak pulse current

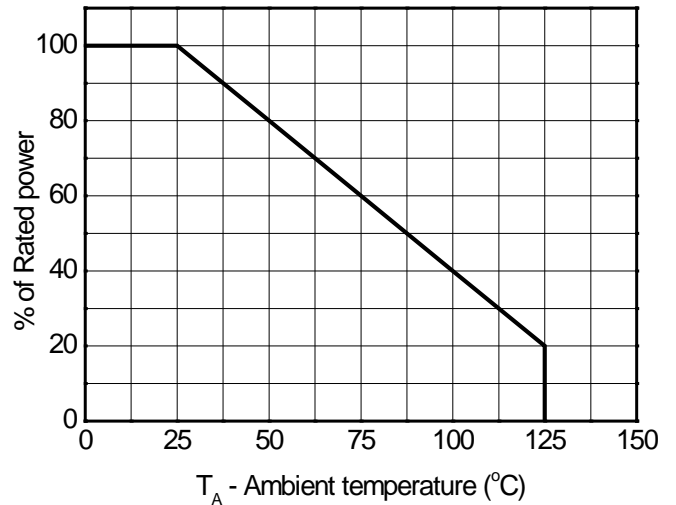

Power derating vs. Ambient temperature

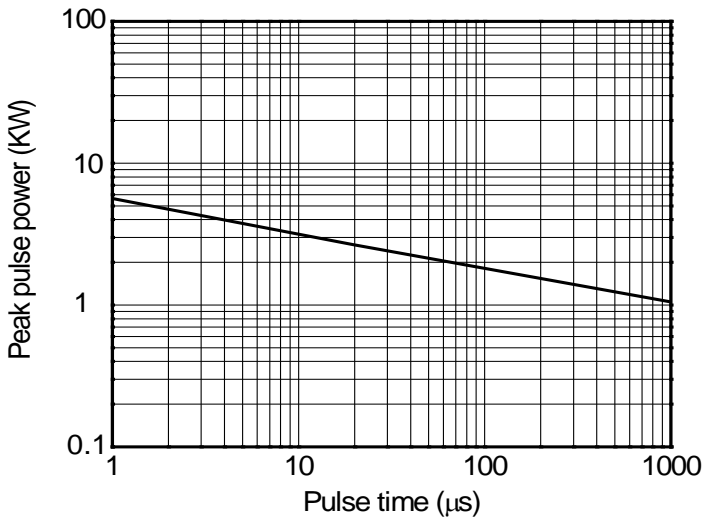

Non-repetitive peak pulse power vs. Pulse time

ESD clamping test setup and waveforms

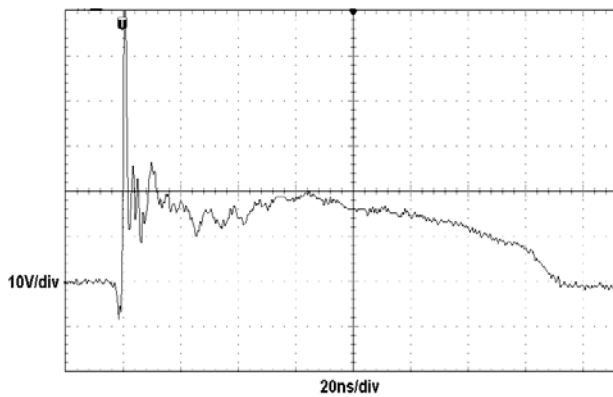
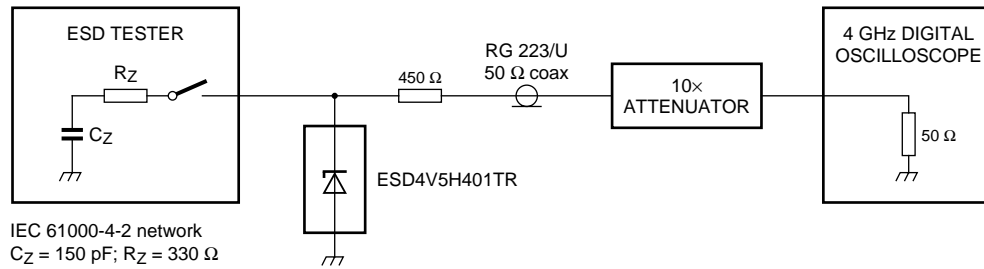

ESD clamping
(+8kV contact discharge per IEC61000-4-2)

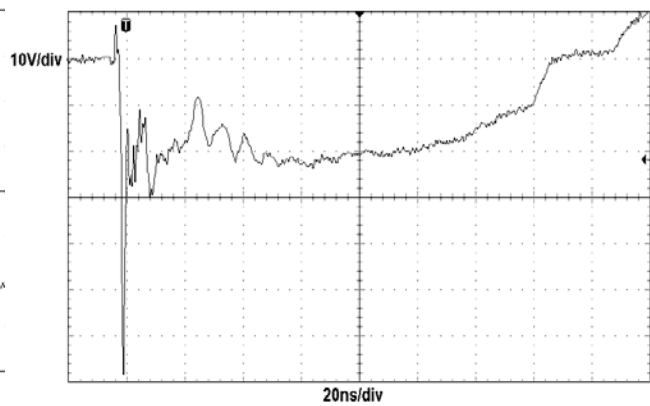

ESD clamping
(-8kV contact discharge per IEC61000-4-2)

Soldering Parameters

Reflow Condition		Pb-Free assembly (see as bellow)
Pre Heat	-Temperature Min ($T_{s(min)}$)	+150°C
	-Temperature Max($T_{s(max)}$)	+200°C
	-Time (Min to Max) (ts)	60-180 secs.
Average ramp up rate (Liquid us Temp (T_L) to peak)		3°C/sec. Max
$T_{s(max)}$ to T_L - Ramp-up Rate		3°C/sec. Max
Reflow	-Temperature(T_L) (Liquid us)	+217°C
	-Temperature(t_L)	60-150 secs.
Peak Temp (T_p)		+260(+0/-5)°C
Time within 5°C of actual Peak Temp (t_p)		30 secs. Max
Ramp-down Rate		6°C/sec. Max
Time 25°C to Peak Temp (T_P)		8 min. Max
Do not exceed		+260°C

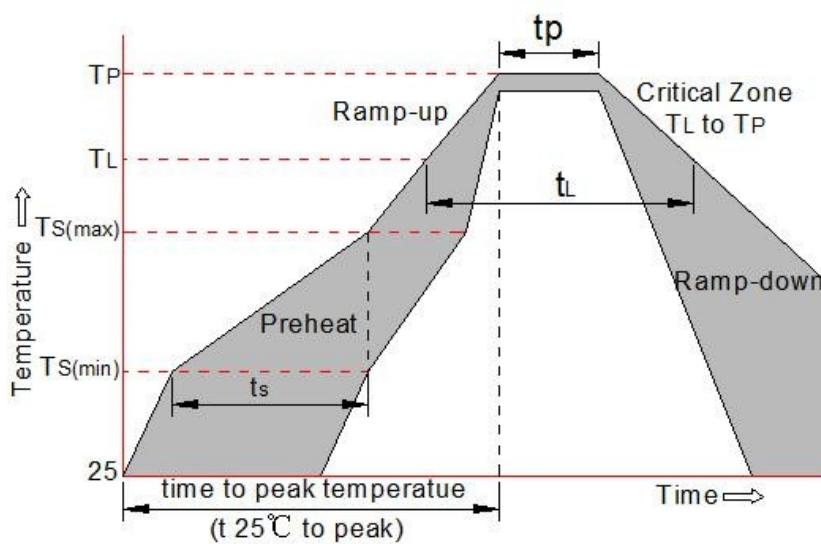

DFN1610-2L Package Outline Drawing

DFN1610

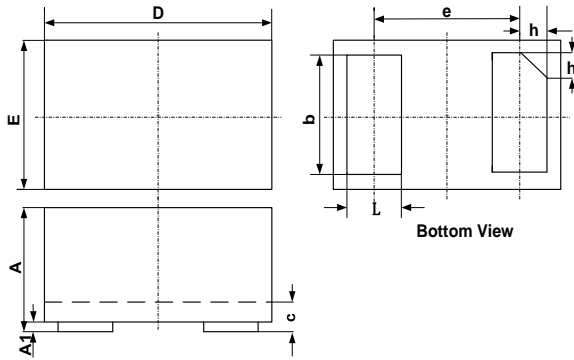

SYM	DIMENSIONS					
	MILLIMETERS			INCHES		
	MIN	NOM	MAX	MIN	NOM	MAX
A	0.45	0.50	0.55	0.018	0.020	0.022
A1	0.00	0.02	0.05	0.000	0.001	0.002
b	0.75	0.80	0.85	0.030	0.032	0.034
c	0.10	0.15	0.20	0.004	0.006	0.008
D	1.55	1.60	1.65	0.062	0.064	0.066
e	1.10 BSC			0.044 BSC		
E	0.95	1.00	1.05	0.038	0.040	0.042
L	0.35	0.40	0.45	0.014	0.016	0.018
h	0.15	0.20	0.25	0.006	0.008	0.010

Suggested Land Pattern

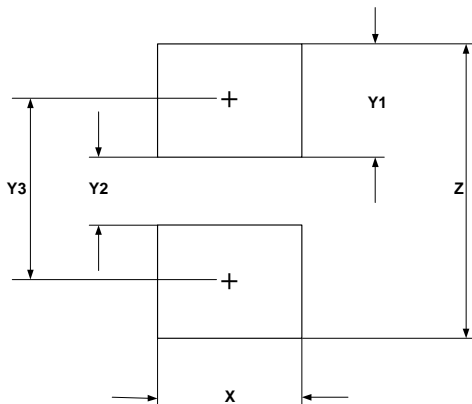

SYM	DIMENSIONS	
	MILLIMETERS	INCHES
X	1.00	0.040
Y1	0.62	0.025
Y2	0.60	0.024
Y3	1.22	0.049
Z	1.85	0.074