

1-Line, Unidirectional Transient Voltage Suppressors

Descriptions

The ESD36B400TR is a Unidirectional TVS (Transient Voltage Suppressor). It is specifically designed to protect sensitive electronic components that may be subjected to ESD (Electrostatic Discharge), EFT (Electrical Fast Transients) and Lightning. It is particularly well-suited for cellular phones, portable device, digital cameras, power supplies and many other portable applications because of its small package and low weight.

The ESD36B400TR may be used to provide ESD protection up to $\pm 30\text{kV}$ air discharge $\pm 30\text{kV}$ contact discharge according to IEC61000-4-2, and withstand peak pulse current up to 6.5A (8/20 μs) according to IEC61000-4-5.



SOD-523

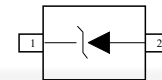
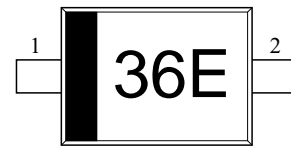

Circuit diagram

Features

- Stand-off voltage: 36V Max
- Transient protection for each line according to IEC61000-4-2 (ESD): $\pm 30\text{kV}$ air discharge $\pm 30\text{kV}$ contact discharge IEC61000-4-4 (EFT): 40A (5/50ns) IEC61000-4-5 (surge): 6.5A (8/20 μs)
- Solid-state silicon technology
- Low leakage current

Applications

- Cell phone handsets and accessories
- Personal Digital Assistants (PDAs)
- Notebooks, Desktops, and Servers
- Portable Instrumentation
- Digital Cameras
- MID/CAR DVD/MP3/MP4/PMP Players

Order information

Device	Package	Shipping
ESD36B400TR	SOD-523	3000/Tape&Reel

Absolute maximum ratings

Parameter	Symbol	Rating	Unit
Peak pulse current ($t_p = 8/20\mu s$)	I_{PP}	6.5	A
ESD according to IEC61000-4-2 air discharge	V_{ESD}	± 30	kV
ESD according to IEC61000-4-2 contact discharge		± 30	
Operation junction temperature	T_J	-55~150	$^{\circ}C$
Lead temperature	T_L	260	$^{\circ}C$
Storage temperature	T_{STG}	-55~150	$^{\circ}C$

Electrical characteristics (TA=25 $^{\circ}C$, unless otherwise noted)

Parameter	Symbol	Condition	Min.	Typ.	Max.	Unit
Reverse stand-off voltage	V_{RWM}				36.0	V
Reverse leakage current	I_R	$V_{RWM} = 36V$			0.2	μA
Reveres breakdown voltage	V_{BR12}	$I_T = 1mA$	37.0			V
Clamping voltage	V_C	$I_{pp} = 1A$ $t_p = 8/20\mu s$			42.0	
		$I_{pp} = 6.5A$ $t_p = 8/20\mu s$			65.0	V
Junction capacitance	C_J	$V_R = 0V, f = 1MHz$		40.0	60.0	pF

Electrical performance curve

Symbol	Parameter
I_{PP}	Maximum Reverse Peak Pulse Current
V_C	Clamping Voltage @ I_{PP}
V_{RWM}	Working Peak Reverse Voltage
I_R	Maximum Reverse Leakage Current @ V_{RWM}
I_T	Test Current
V_{BR}	Breakdown Voltage @ I_T
I_F	Forward Current
V_F	Forward Voltage @ I_F

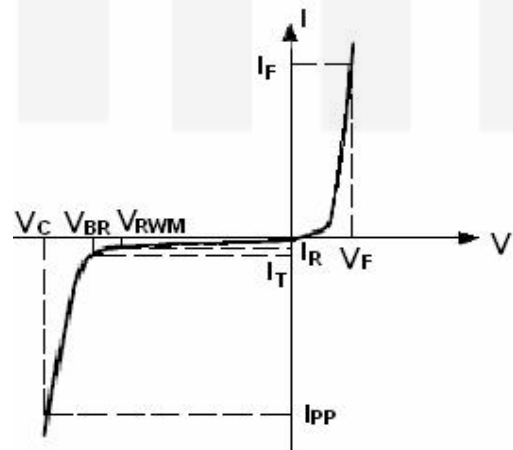

Typical characteristics ($T_A=25^\circ\text{C}$, unless otherwise noted)

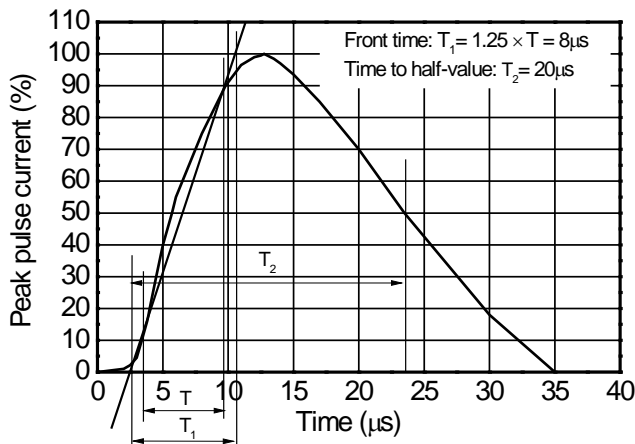

8/20 μs waveform per IEC61000-4-5

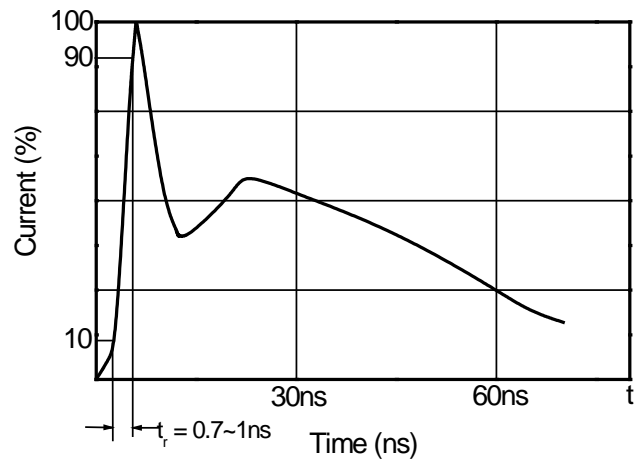

Contact discharge current waveform per IEC61000-4-2

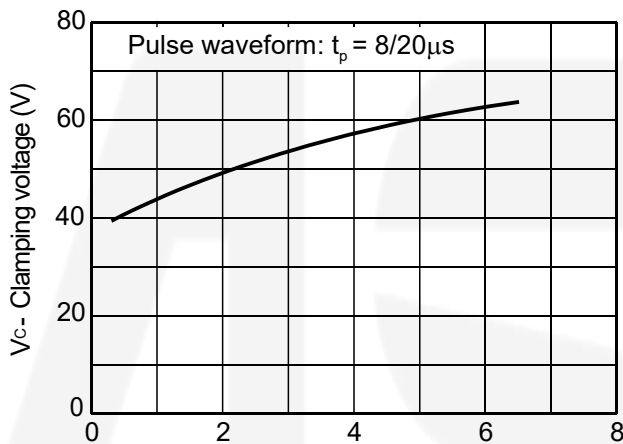

Clamping voltage vs. Peak pulse current

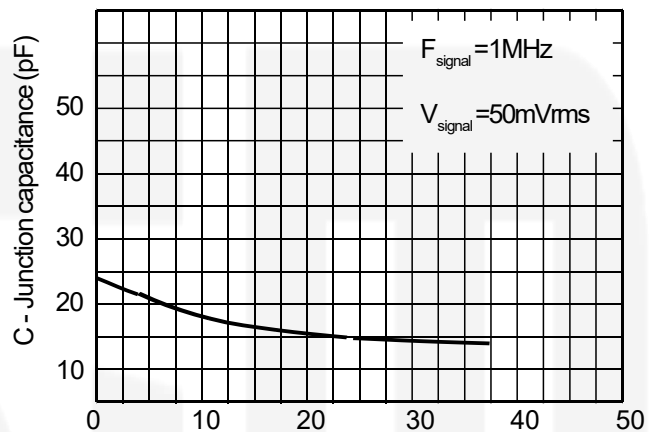

Capacitance vs. Reverses voltage

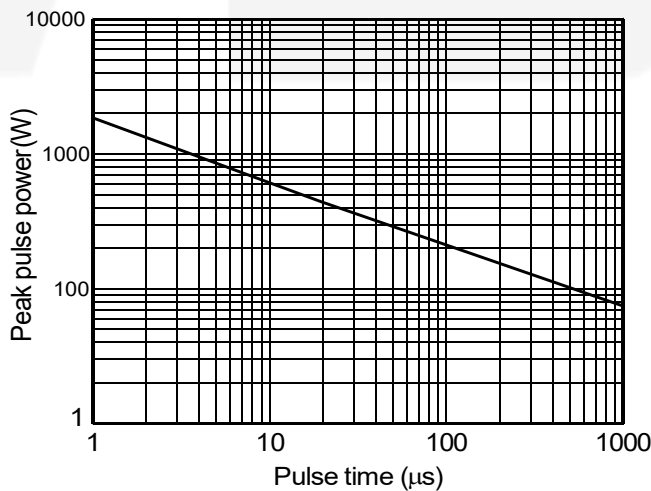

Non-repetitive peak pulse power vs. Pulse time

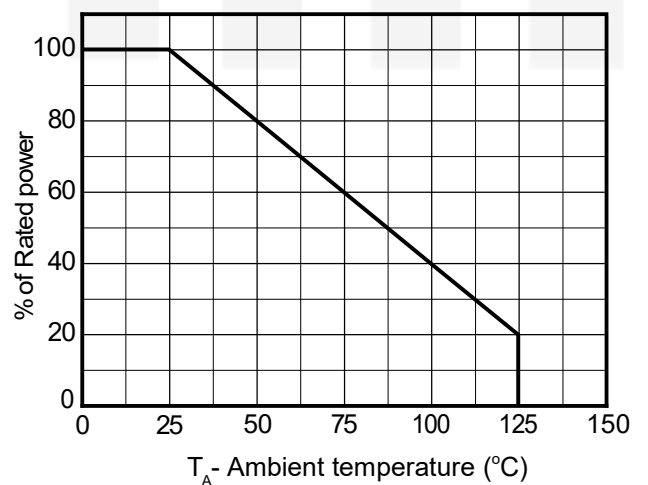

Power derating vs. Ambient temperature

ESD clamping test setup and waveforms

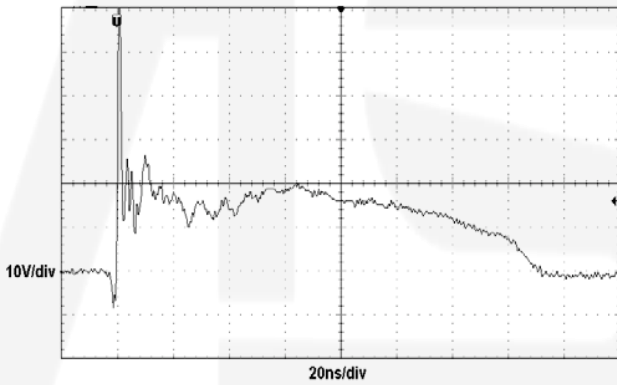
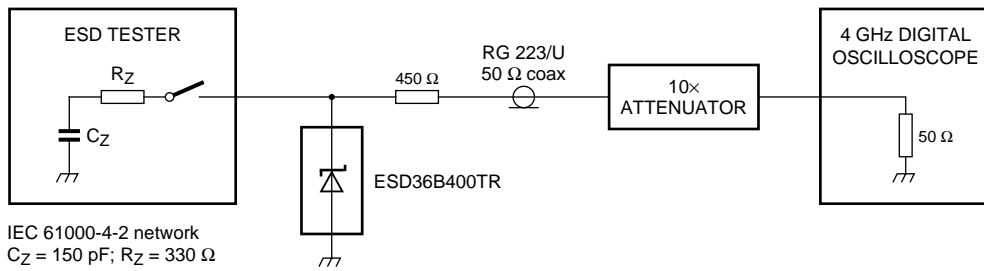

ESD clamping
 (+8kV contact discharge per IEC61000-4-2)

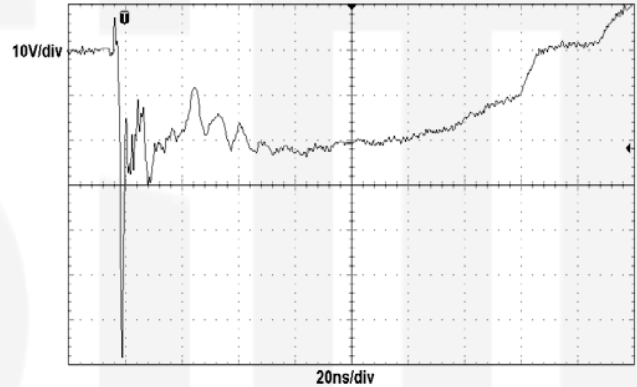

ESD clamping
 (-8kV contact discharge per IEC61000-4-2)

Package outline dimensions

SOD-523

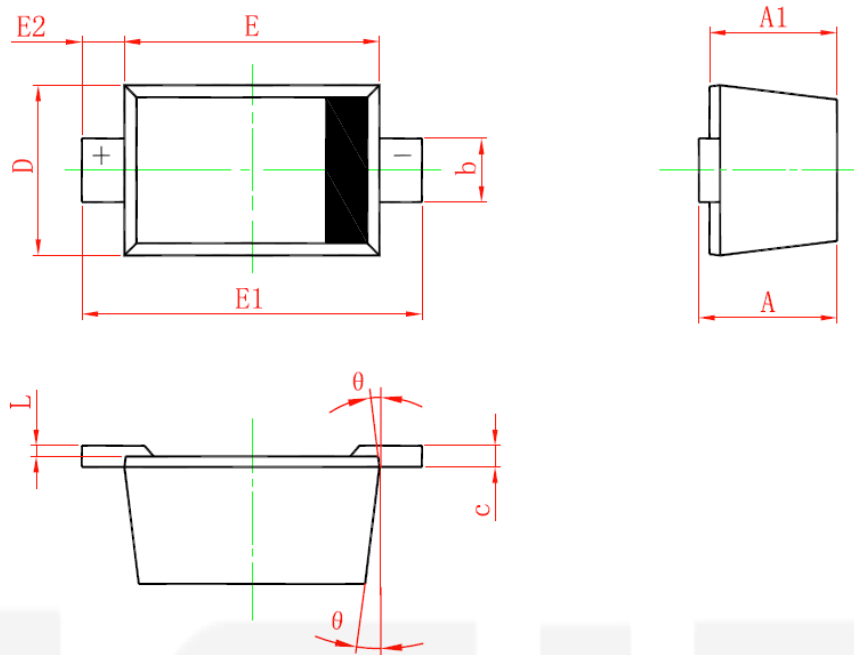

Symbol	Dimensions in millimeter		
	Min.	Typ.	Max.
A	0.510	0.640	0.770
A1	0.500	0.600	0.700
b	0.250	0.300	0.350
c	0.080	0.115	0.150
D	0.700	0.800	0.900
E	1.100	1.200	1.300
E1	1.500	1.600	1.700
E2	0.200 Ref		
L	0.010	0.040	0.070
θ	7° Ref		

Recommend land pattern (Unit: mm)

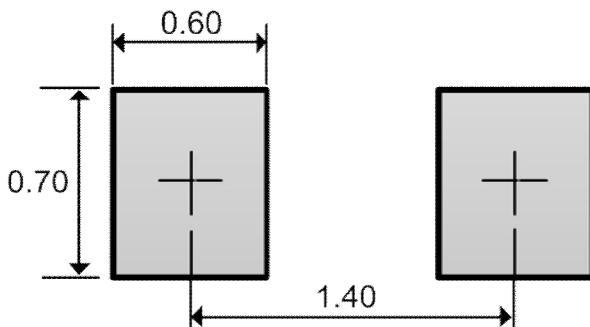

Note: This land pattern is for your reference only. Actual pad layouts may vary depending on application.